



**SCHEMATIC REFERENCE**

---

**SNOWDOGG LIGHT REFERENCE**

GENERAL SCHEMATIC/KEY	4
STANDARD INSTALLATION SCHEMATIC	5
SWITCHED GROUND SCHEMATIC	9

## SCHEMATIC REFERENCE

---

### Welcome

This manual contains schematics detailing the G2 SnowDogg headlight circuit. While this is useful, it is only intended as reference for preliminary troubleshooting. **It is often much faster to replace a harness than it is to do extensive troubleshooting.**

In new installations, MOST light malfunctions are due to installation errors or the wrong adapter. Before beginning any extensive troubleshooting, double check the application and installation and check the [www.snowdoggplows.com](http://www.snowdoggplows.com) website for updated installation instructions and technical service bulletins.

Contact your dealer promptly for technical assistance – all lighting issues can usually be resolved very quickly, and those that cannot are usually due to an issue with the vehicle side circuit.

**Always verify that ALL light circuits on the vehicle are working properly before beginning plow installation.** Aftermarket accessories like Remote Starters, HID kits, non-factory headlights, existing plow installations, can cause an installation to fail. It may be necessary to remove aftermarket components to ensure the proper operation of the plow lights.

# SCHEMATIC REFERENCE

## GENERAL SCHEMATIC - STANDARD SWITCHED TRUCK

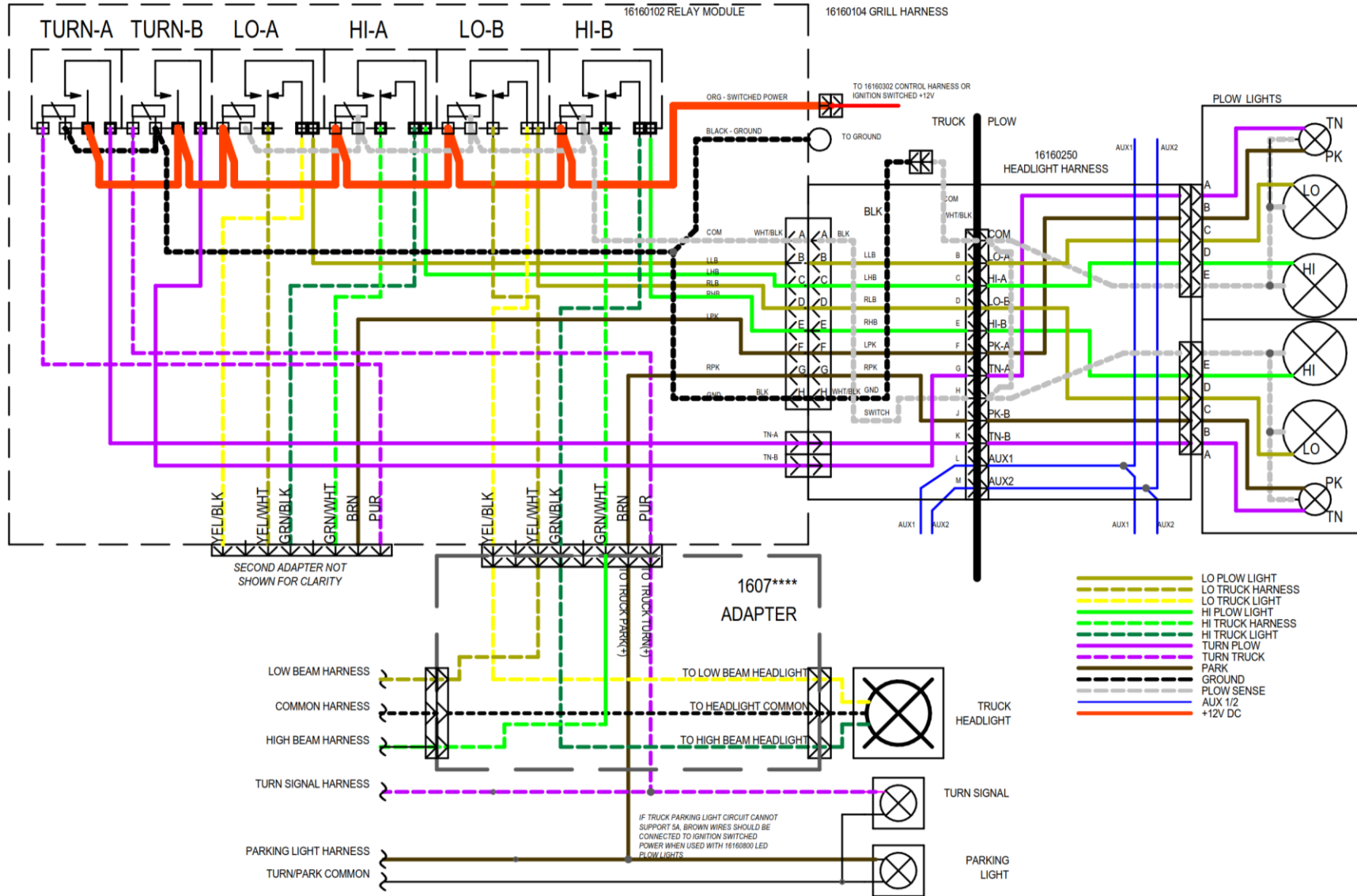

# SCHEMATIC REFERENCE

## PLOW DISCONNECTED - TRUCK ON - STANDARD SWITCHED TRUCK

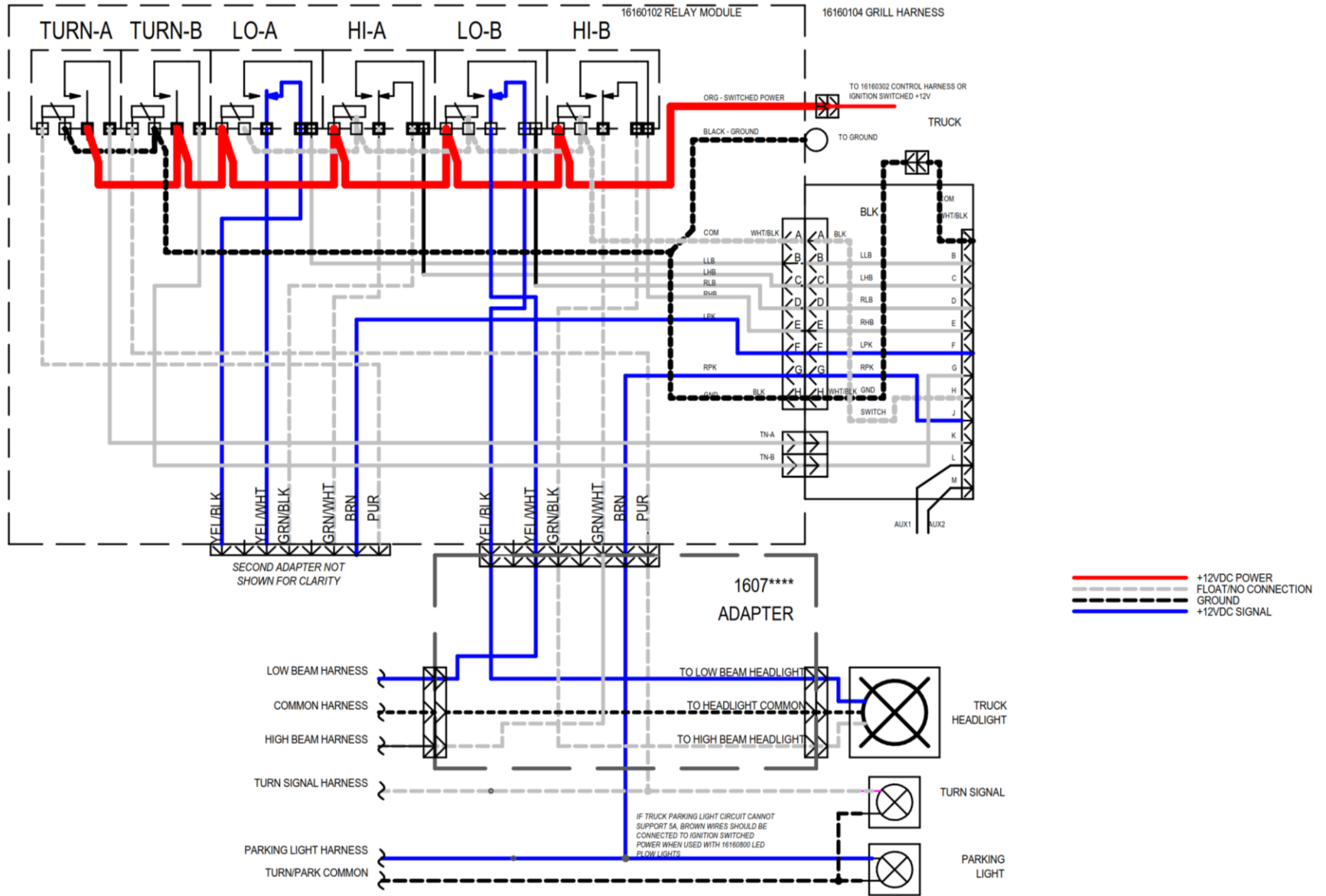

# SCHEMATIC REFERENCE

## PLOW CONNECTED - TRUCK ON - LOW BEAM/MARKER LIGHTS - STANDARD SWITCHED TRUCK

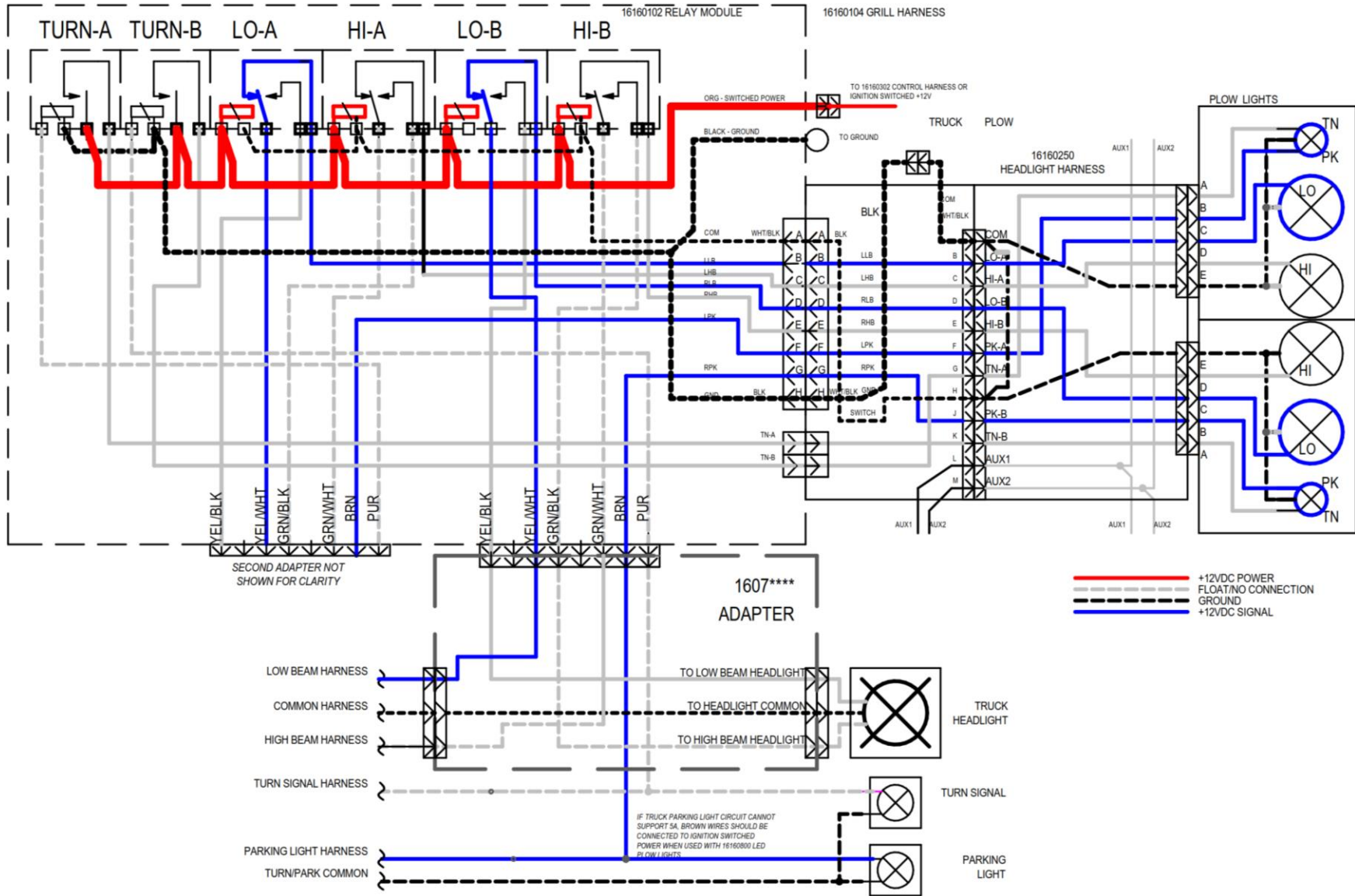



# SCHEMATIC REFERENCE

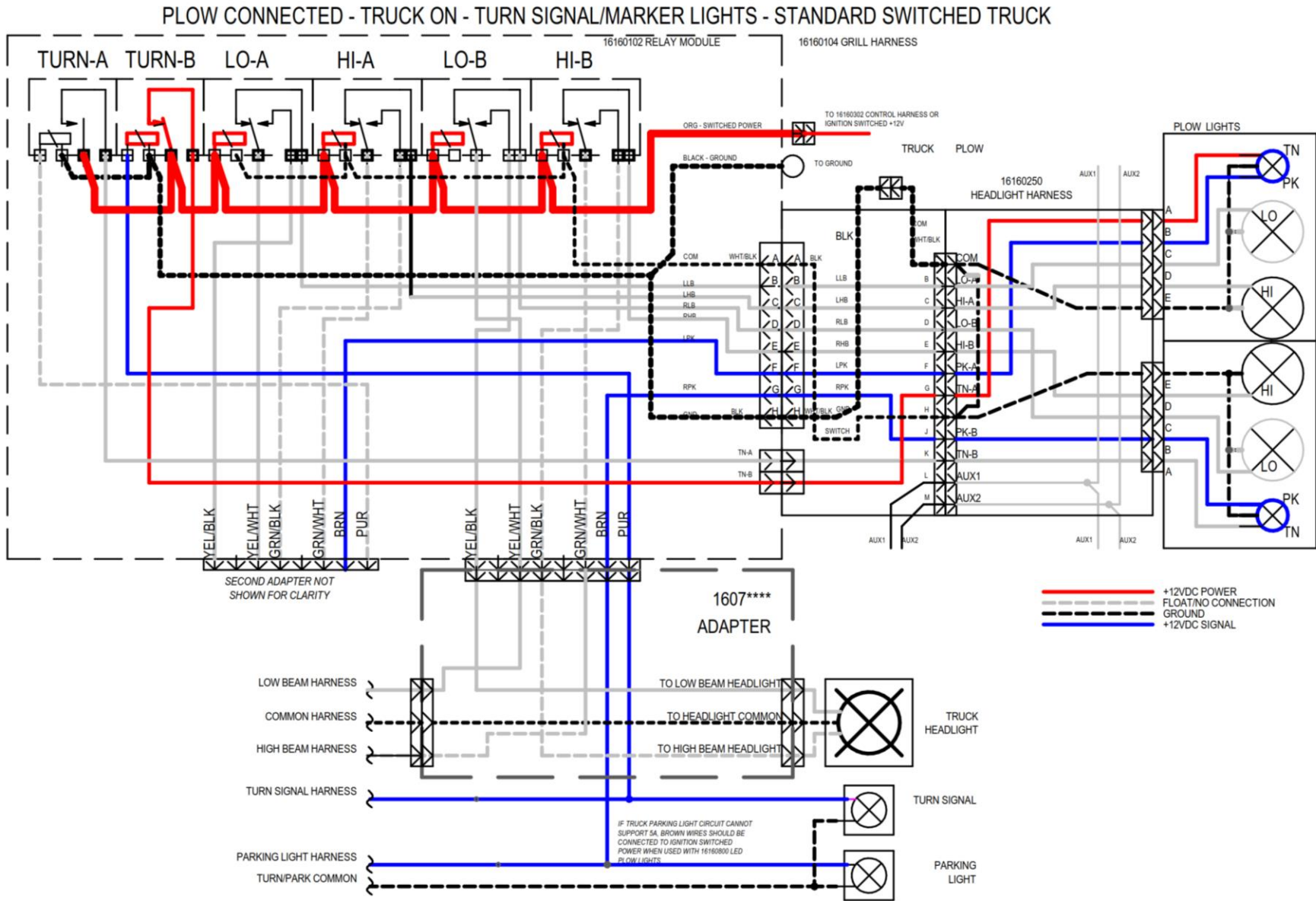

# SCHEMATIC REFERENCE

## GENERAL SCHEMATIC - SWITCHED GROUND TRUCK

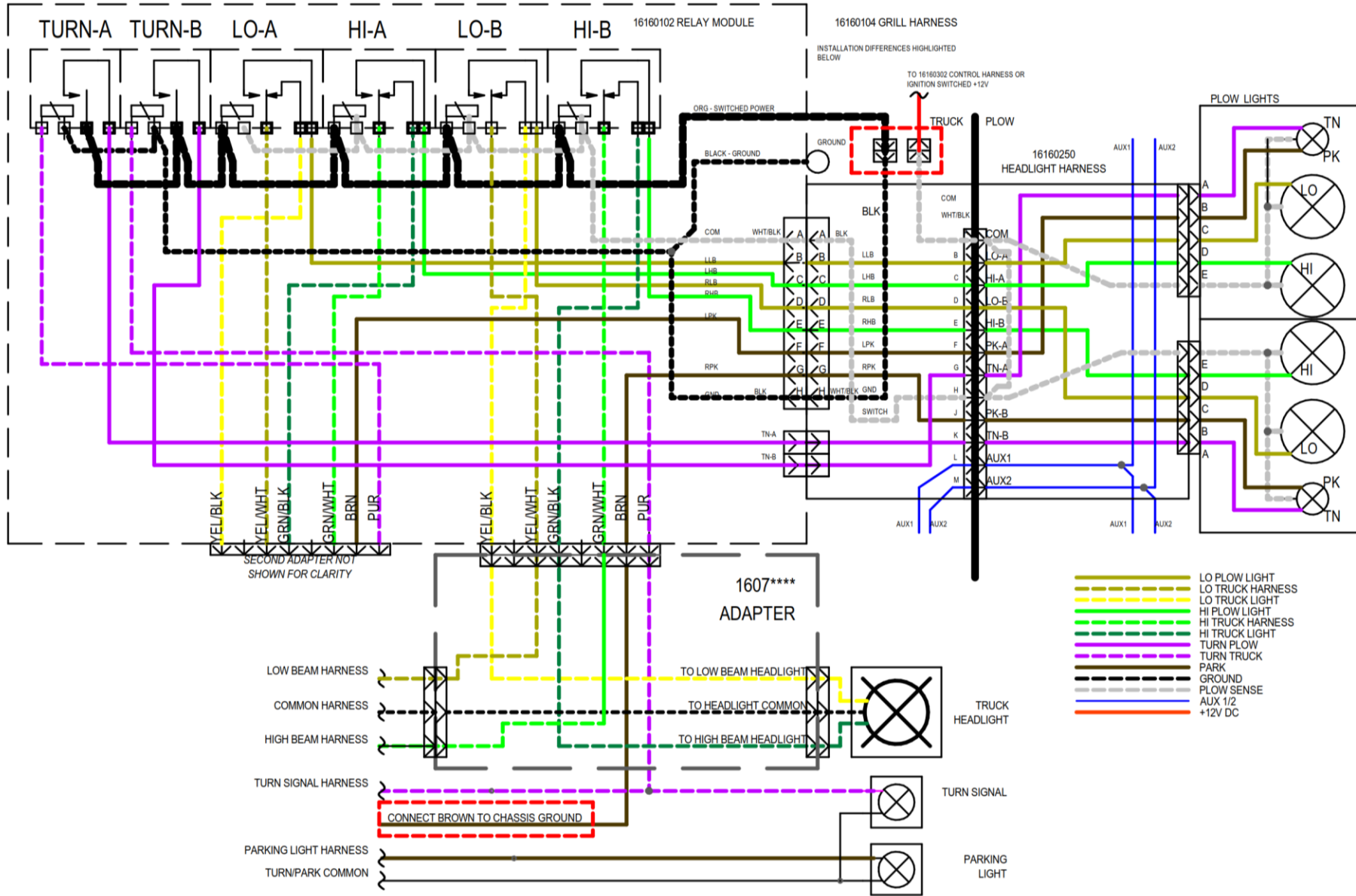

# SCHEMATIC REFERENCE

## PLOW DISCONNECTED - TRUCK ON - SWITCHED GROUND

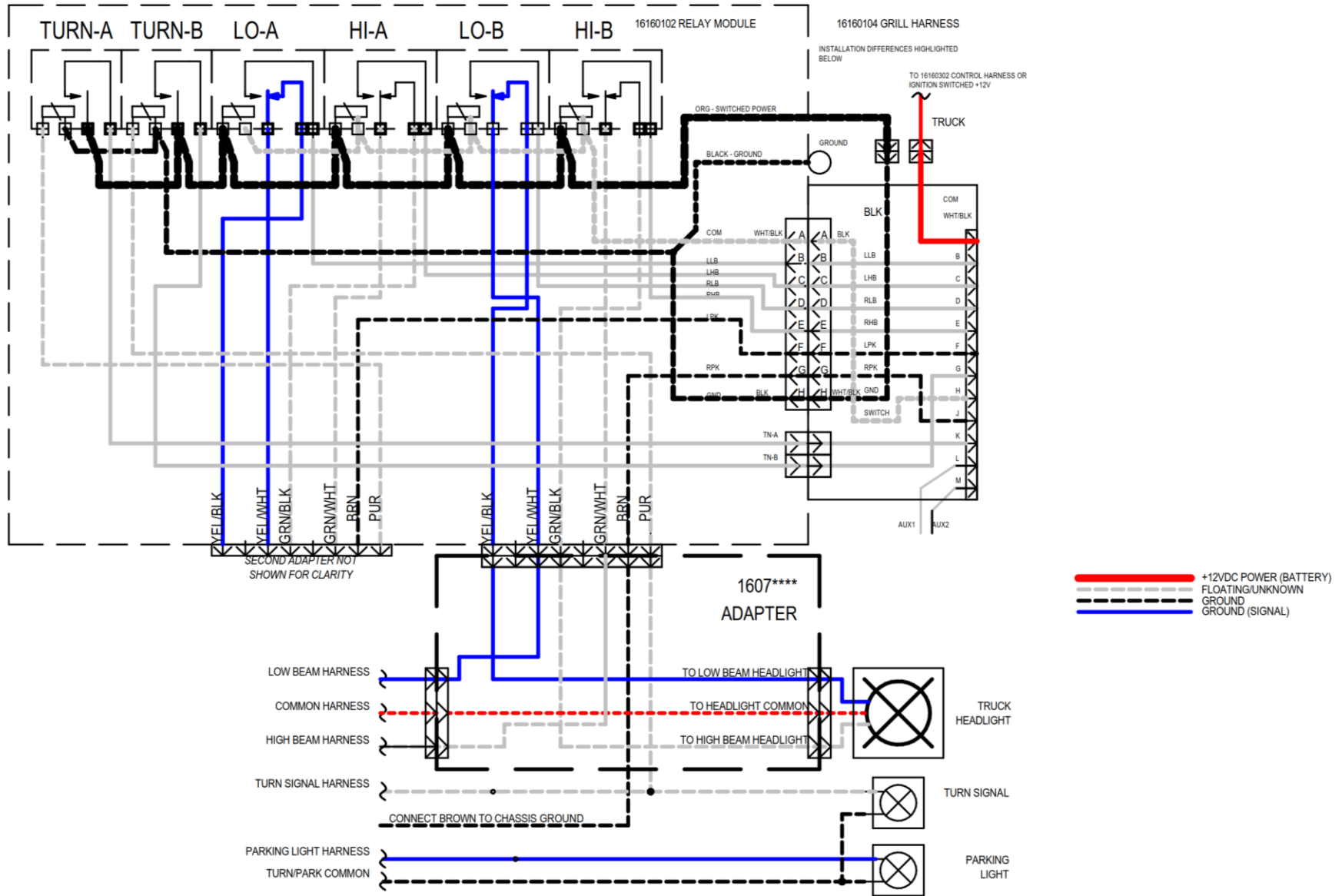

# SCHEMATIC REFERENCE

## PLOW CONNECTED - TRUCK ON - LOW BEAM/MARKER LIGHTS - SWITCHED GROUND

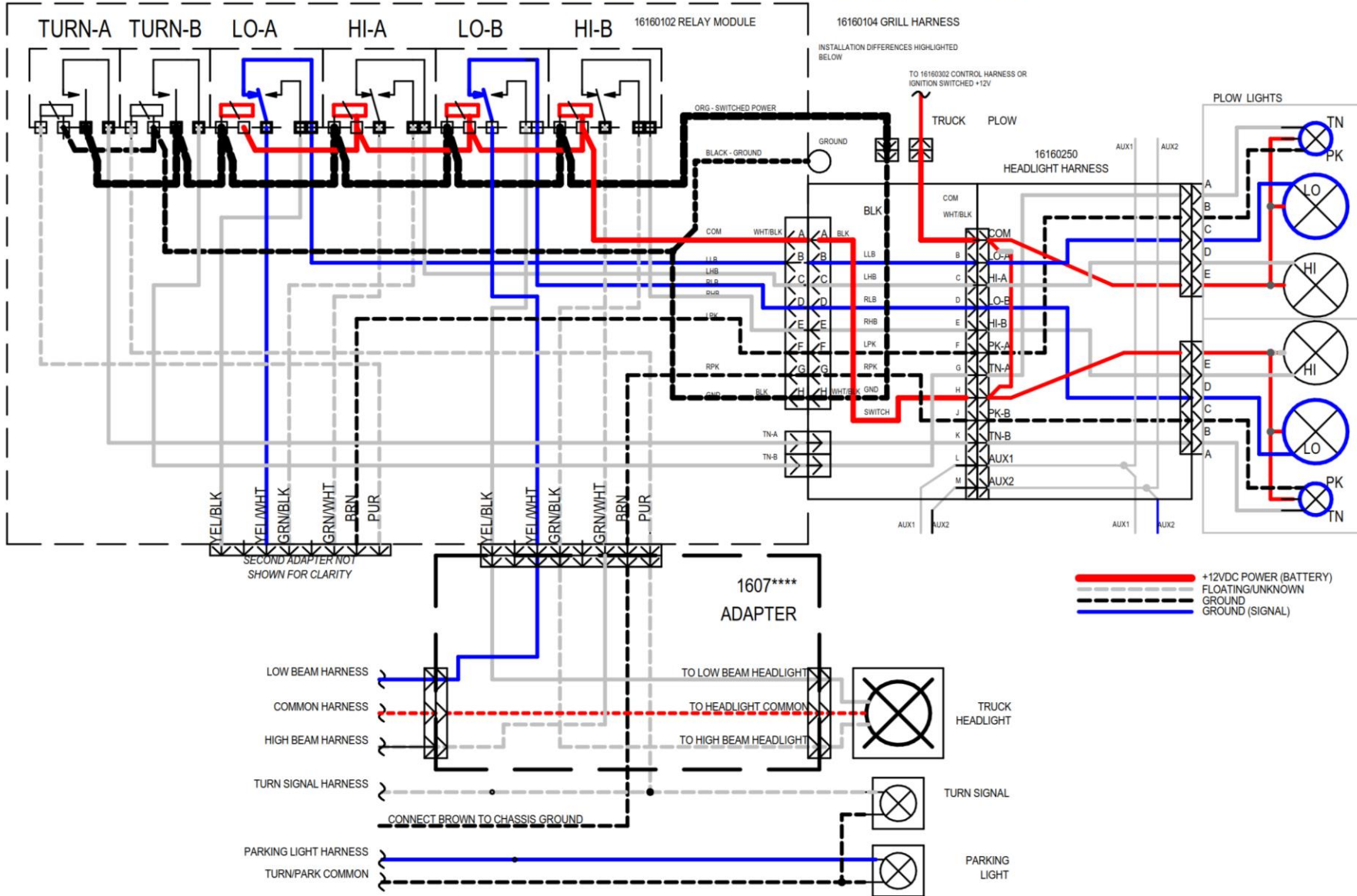

# SCHEMATIC REFERENCE

## PLOW CONNECTED - TRUCK ON - HIGH BEAM/MARKER LIGHTS - SWITCHED GROUND

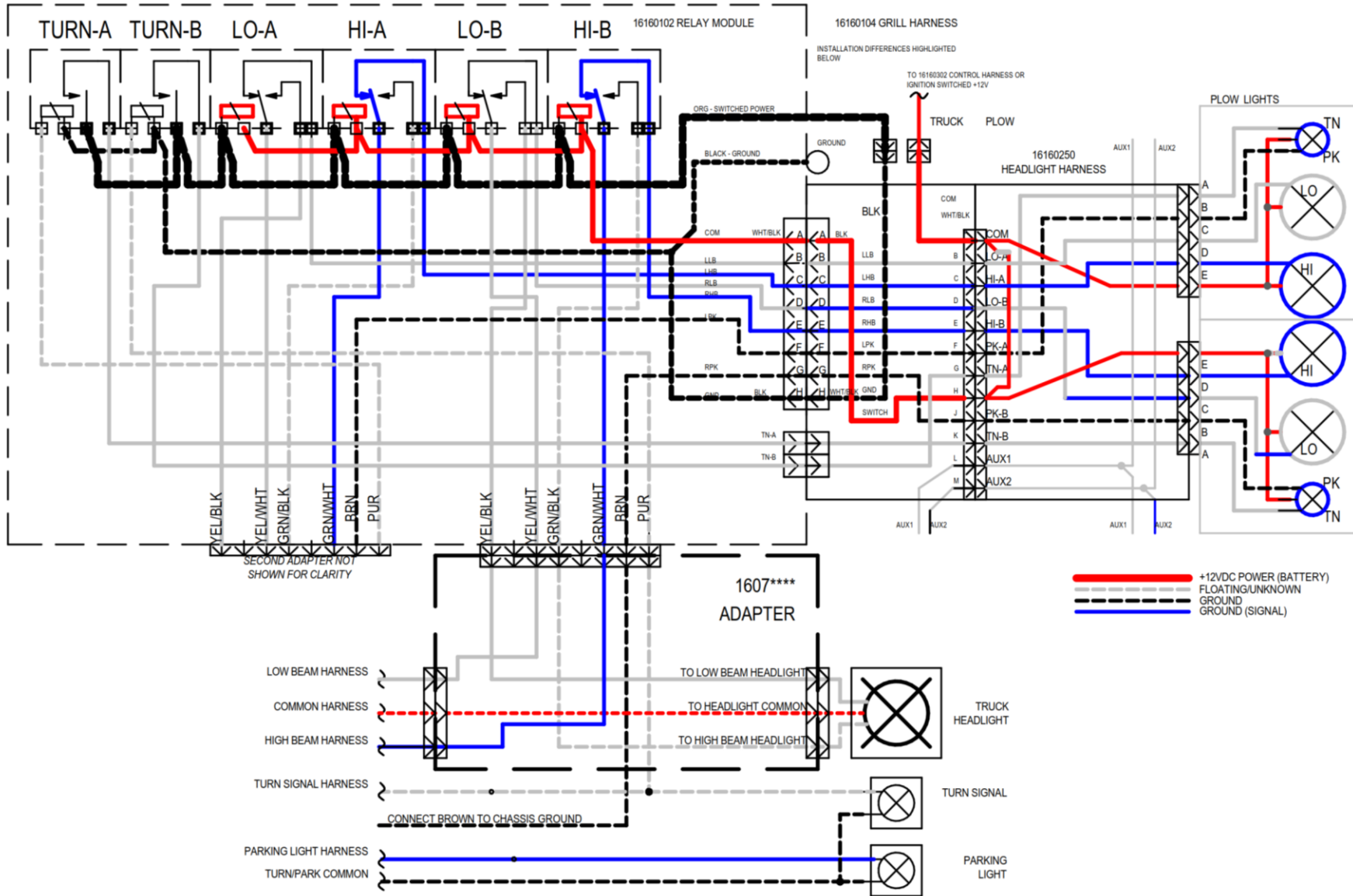

# SCHEMATIC REFERENCE

## PLOW CONNECTED - TRUCK ON - TURN SIGNAL/MARKER LIGHTS - SWITCHED GROUND

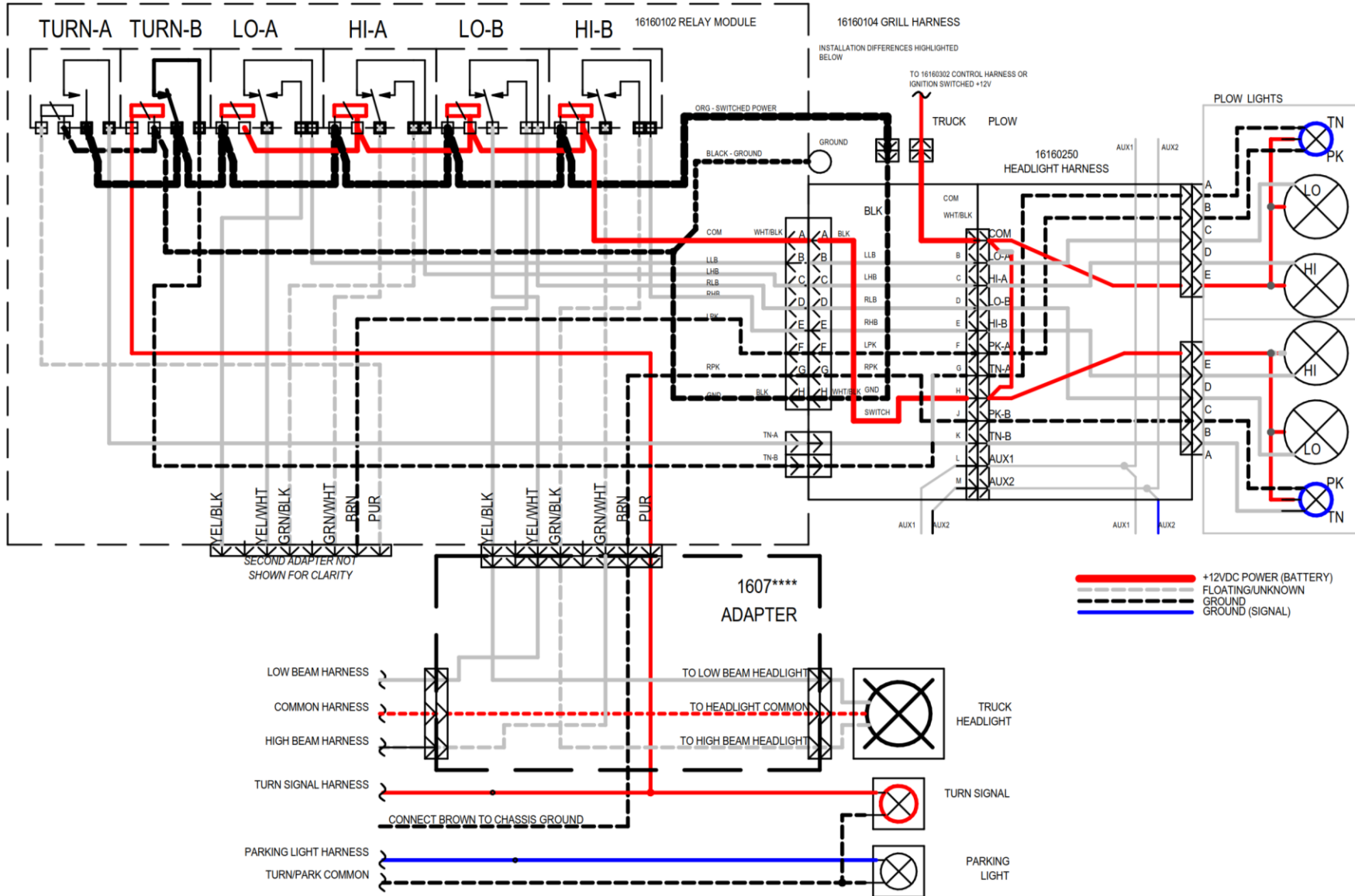

**SCHEMATIC REFERENCE**

---